



6 Fen Road
East Kirkby, Spilsby, Lincolnshire, PE23 4DB

£159,950

2 Bedroom Detached Bungalow

- Freehold
- No Onward Chain
- Two Bedroom Bungalow
- Located Within A Semi-Rural Village
- Detached Garage
- Conservatory
- Viewing Advised
- Generous Gardens With Ample Parking
- EPC Rating - C, Council Tax Band - B

[Click here to access the Energy Performance Certificate for 6 Fen Road, East Kirkby, Spilsby, Lincolnshire, PE23 4DB](#)



Overview

Detached Bungalow in the Popular Village of East Kirkby - No Onward Chain

Situated within the popular village of East Kirkby, this detached bungalow offers well-presented accommodation throughout and is available with the added benefit of no onward chain.

The accommodation comprises an entrance hall, fitted kitchen, spacious lounge/dining room, conservatory, two bedrooms and a shower room. The conservatory provides additional reception space and enjoys views over the rear garden.

Externally, the property benefits from a driveway to the front providing off-road parking and leading to a detached garage. There are gardens to both the front and rear, providing pleasant outdoor space to enjoy throughout the year.

East Kirkby is a well-regarded Lincolnshire village offering a range of local amenities whilst remaining conveniently positioned for access to Horncastle, Spilsby and the Lincolnshire coast. Surrounded by attractive countryside, it is an ideal location for those seeking village living.

Viewing is highly recommended to appreciate the accommodation on offer.





Ground Floor

Approx. 80.8 sq. metres (869.4 sq. feet)

Garage to Rear Right

Approx. 22.1 sq. metres (237.8 sq. feet)

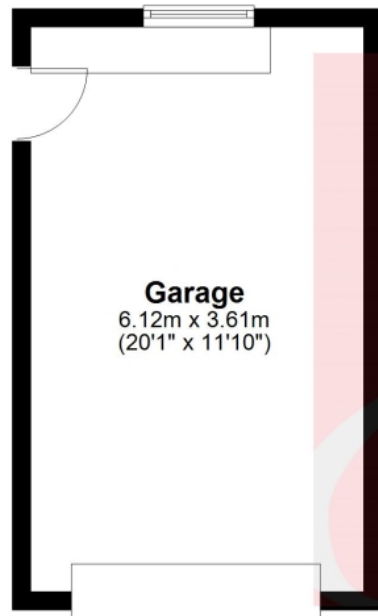

Conservatory

2.66m x 5.61m
(8'9" x 18'5")

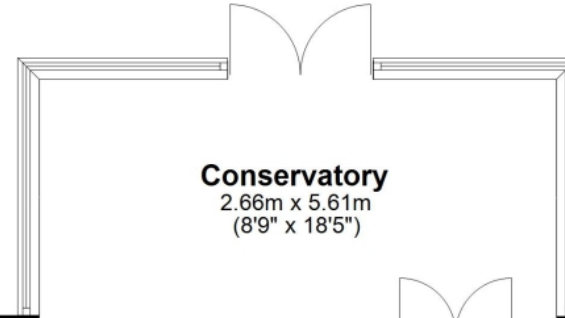

Bedroom 1

3.89m x 3.27m
(12'9" x 10'9")

Bedroom 2

2.54m x 3.52m
(8'4" x 11'7")

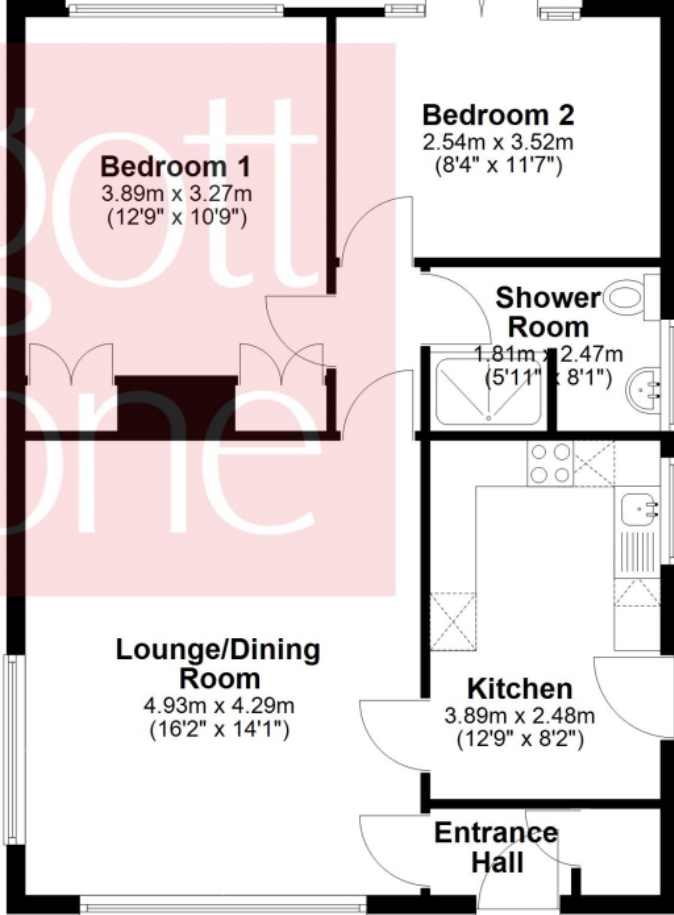

Shower Room

1.81m x 2.47m
(5'11" x 8'1")

Lounge/Dining Room

4.93m x 4.29m
(16'2" x 14'1")

Kitchen

3.89m x 2.48m
(12'9" x 8'2")

Entrance Hall

Total area: approx. 102.9 sq. metres (1107.2 sq. feet)

Floor plan created by Matte Black Media.
Plan produced using PlanUp.

Ground Floor

Approx. 80.8 sq. metres (869.4 sq. feet)

Garage to Rear Right

Approx. 22.1 sq. metres (237.8 sq. feet)

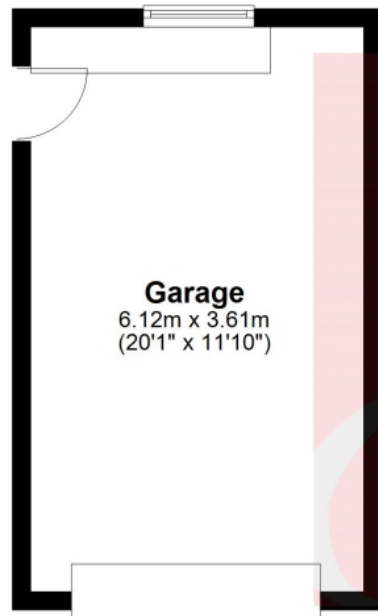

Conservatory

2.66m x 5.61m
(8'9" x 18'5")

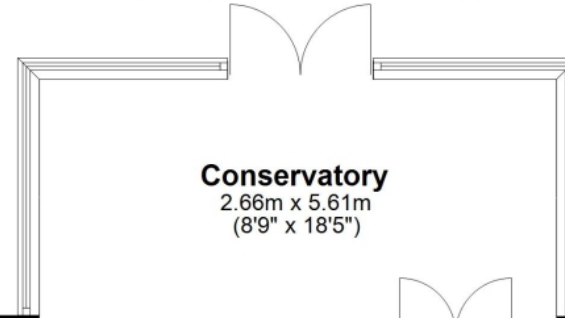

Bedroom 1

3.89m x 3.27m
(12'9" x 10'9")

Bedroom 2

2.54m x 3.52m
(8'4" x 11'7")

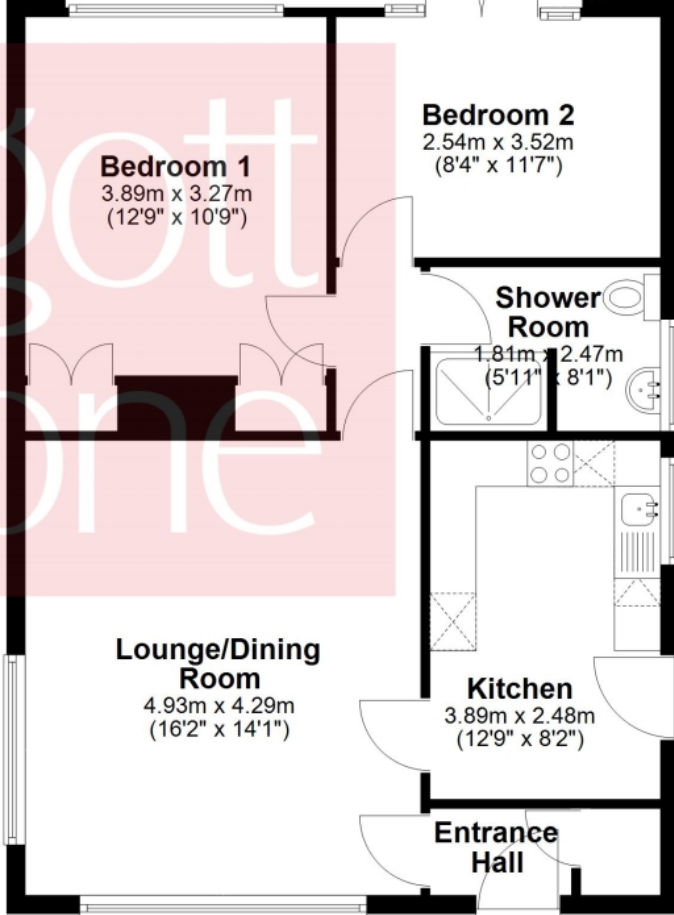

Total area: approx. 102.9 sq. metres (1107.2 sq. feet)

Floor plan created by Matte Black Media.
Plan produced using PlanUp.





Entrance Hall

Lounge/Dining Room 4.93 x 4.29m

Location

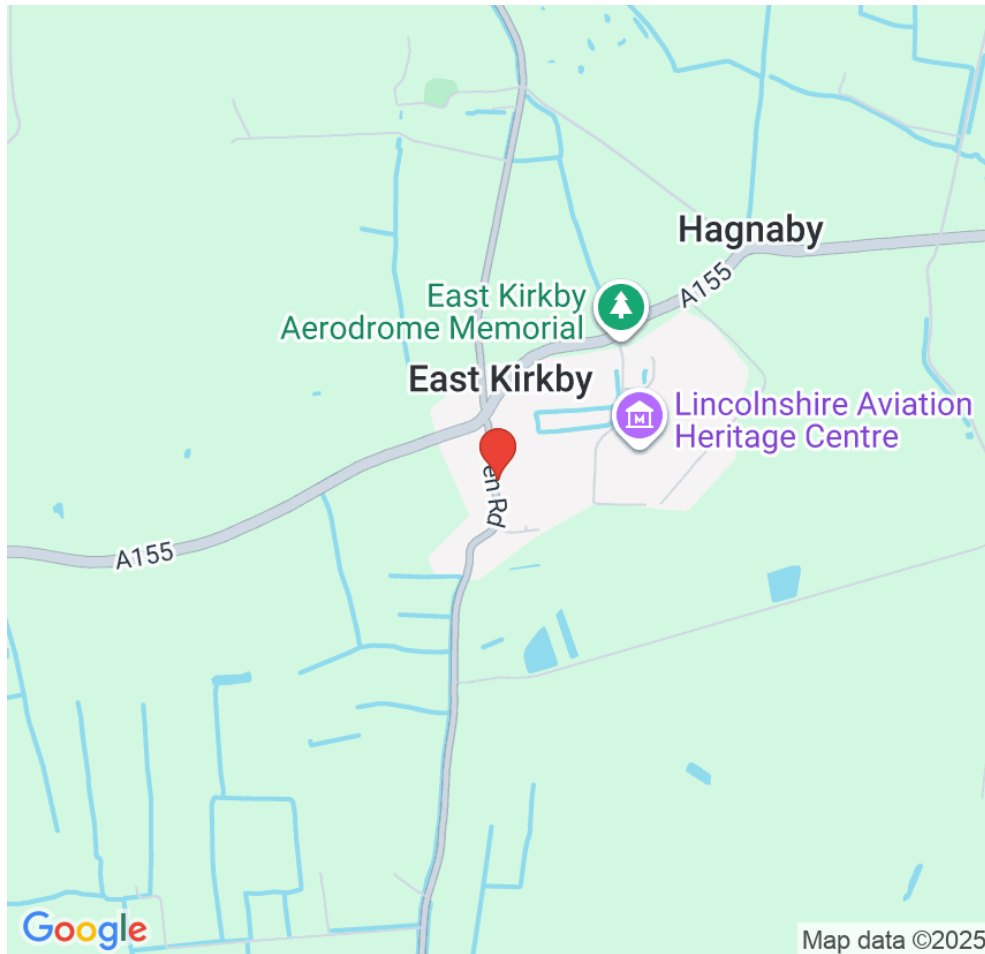

Show on Google: [schools](#), [doctors](#), [supermarkets](#), [restaurants](#), [railway stations](#)



Stonebow
Financial Services Ltd

Do you need Financial Help or Advice?

We are offering free advice through Mortgage Advice Bureau. If you would like to discuss your finances or mortgage, we'll arrange for a qualified adviser to call you back at a convenient time.

0330 912 0007

Your home may be repossessed if you do not keep up repayments on your mortgage.

There may be a fee for mortgage advice. The actual amount you pay will depend upon your circumstances. The fee is up to 1% but a typical fee is 0.3% of the amount borrowed.



Houses. Homes. Harmony.



6 Fen Road, East Kirkby
is on the market with our Boston branch

24 Wide Bargate, Boston PE21 6RX

01205 359111